

Operating Instructions

STAHlwILLE

**Sensotork Electronic Workshop Torque Tester
7707-1-2W, 7707-1-3W, 7707-1W, 7707-2W,
7707-2-1W, 7707-2-2W and 7707-3W**

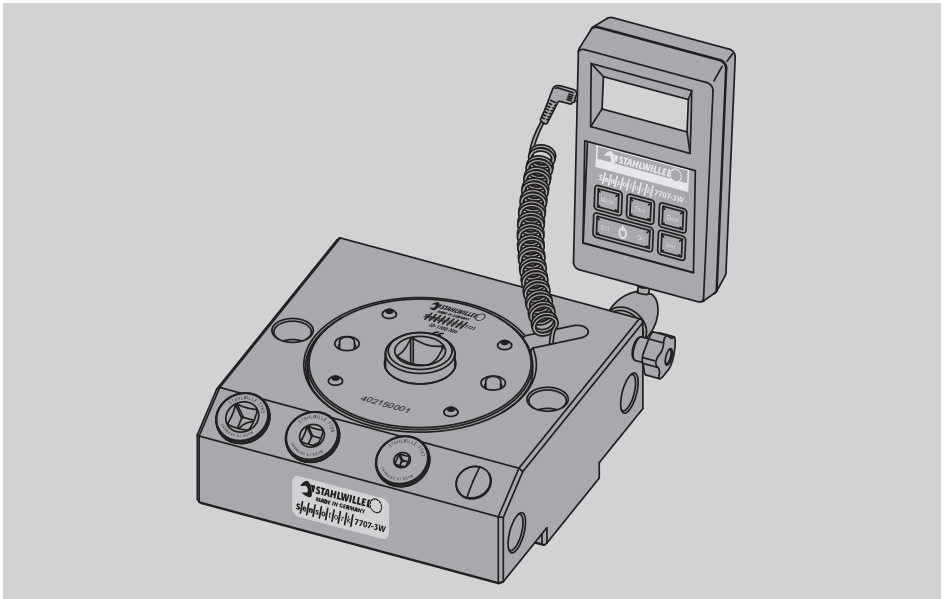

Please ensure you read these Operating Instructions carefully to ensure you operate the equipment correctly and safely and keep these instructions in an accessible place.

Preface

These Operating Instructions will assist you in using the electronic workshop torque testers, models 7707-1W, 7707-1-2W, 7707-1-3W, 7707-2W, 7707-2-1W, 7707-2-2W and 7707-3W,

- safely,
- economically and
- in accordance with the intended purpose.

Target group for these Operating Instructions

The Operating Instructions are design for use with the electronic workshop torque testers models 7707-1W, 7707-1-2W, 7707-1-3W, 7707-2W, 7707-2-1W, 7707-2-2W, 7707-3W.

The information contained in the Operating Instructions is for authorised, qualified, instructed personnel. It is assumed that these people will have generally applicable technical knowledge.

Any person

- transporting,
- setting up,
- dismantling,
- operating,
- servicing or
- disposing

of this electronic torque tester for torque wrenches or torque screwdrivers is expected to have read and understood the corresponding sections of these Operating Instructions.

If, for any reason, you do not understand any of the information in these Operating Instructions or feel there is some important information missing, please contact Eduard Wille GmbH & Co. KG.

Contents

Introduction to the Operating Instructions	5
Structural features of the information on dangers	5
Structural features of notices referring to property damage	5
Availability	6
Addenda	6
Conventions used in these Instructions	6
Fundamental safety instructions	7
Intended purpose and field of application	7
Obligations relating to the Operating Instructions	8
CE symbol	8
Fundamental safety instructions	9
Technical description	10
Identification	10
Accuracy	10
Functional description	12
Technical specifications	13
Transport, items supplied, storage	19
Transport	19
Items included	20
Optional accessories	27
Storage	27
Preparing and mounting the electronic workshop torque tester	28
General fitting instructions	28
Mounting the electronic workshop torque tester	29
Attaching the display unit	32
Attaching the display unit to the mounting block	32
Fixing the display unit on the stand	36

Inserting and removing transducers	38
Inserting the transducer	38
Releasing the transducer	39
Connecting the display unit	40
Connecting a USB-adapter (optional)	44
Switching the display unit on and off	45
Testing a torque wrench or torque screwdriver	47
Inserting the torque wrench or torque screwdriver	48
Reading off measurements via the display unit	51
Testing indicating torque wrenches or torque screwdrivers . . .	54
Maintenance and cleaning	61
Repairs, calibration and adjustment	62
Disposal	63

Introduction to the Operating Instructions

Structural features of the information on dangers

The following categories of notices are contained in these operating instructions:



DANGER

Notices containing the word **DANGER** warn of hazards which lead directly to severe or fatal injuries.



WARNING

Notices containing the word **WARNING** warn of hazards which may possibly lead to severe or fatal injuries.



CAUTION

Notices containing the word **CAUTION** warn of hazards which may possibly lead to slight to moderate injuries.

Structural features of notices referring to property damage

ATTENTION!

Notices containing the word **ATTENTION** warn of possible property damage.

Availability

If these Operating Instructions should be mislaid or become unusable, replacement copies are available from Eduard Wille GmbH & Co. KG. If you have not yet registered your device, you will need the following details to place your order:

- The number of the transducer
- The name of your local distributor
- The date of purchase of the device

The order number is to be found in the bottom left-hand corner of the title page.

Addenda

As legal regulations for the machine location relating to

- accident prevention and
- environmental protection change,

you are required to amend or add to these Operating Instructions.

Conventions used in these Instructions

Throughout these Operating Instructions, certain typographical conventions have been used. This is to underline whether a text is descriptive,

- a list of points or
- a list of actions

to be carried out.



These instructions provide special information on the most economic use of the electronic workshop torque tester for torque wrenches or torque screwdrivers.

Fundamental safety instructions

Intended purpose and field of application

Only use the electronic workshop testers for the purpose of testing torque wrenches or torque screwdrivers as described in these instructions. The 7707-1-3W electronic workshop tester is designed for the calibration and adjustment of indicating and clicking torque screwdrivers as well as for general torque measurement.

The 7707-1W, 7707-1-2W, 7707-2W, 7707-2-1W, 7707-2-2W and 7707-3W electronic workshop torque testers are intended for the calibration and adjustment of indicating and clicking torque wrenches as well as for simply measuring torque.

Any use not conforming to the intended use of the electronic workshop torque tester as described herein can result in damage to property and even personal injury. The "intended purpose" includes full adherence to the information contained in this instruction booklet, in particular the safety instructions and technical tolerance limits.

Furthermore, it is essential to observe all the laws and regulations in force at the location where the tool is to be used.

STAHLWILLE will not accept any liability for damage or injury occurring from use that does not conform with the intended use.



DANGER

Danger due to independent conversions or modifications to the electronic workshop tester.

→ Make sure that no conversions are carried out on the electronic workshop tester.

Obligations relating to the Operating Instructions

The user of the electronic workshop torque tester for torque wrenches or torque screwdrivers is responsible for ensuring that these Operating Instructions are readily available wherever the electronic workshop tester is in use. Always keep the Operating Instructions close to the electronic torque tester.

CE symbol

All electronic workshop torque testers conform with the EU directives and regulations currently in force. The CE mark is to be found on

- the transducer,
- the mains adaptor,
- the front of the display unit
- and the (optional) USB adaptor.

Fundamental safety instructions

The 7707-1W, 7707-1-2W, 7707-1-3W, 7707-2W, 7707-2-1W, 7707-2-2W and 7707-3W electronic workshop torque testers and their display units are precision testing equipment and must be treated with corresponding care. Avoid subjecting the tool to physical knocks, chemicals or excessive temperatures beyond the limits given in these instructions. Damp and dirt can cause malfunctioning and lead to inaccurate readings.

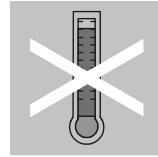

CAUTION

Risk of injury due to overloading the electronic workshop tester.

- Only overload the electronic workshop tester briefly.
 - Do not overload the electronic workshop tester to more than 20% of the maximum value.
-

Technical description

Identification

All the transducers have a serial number on them and are supplied with a works calibration certificate.

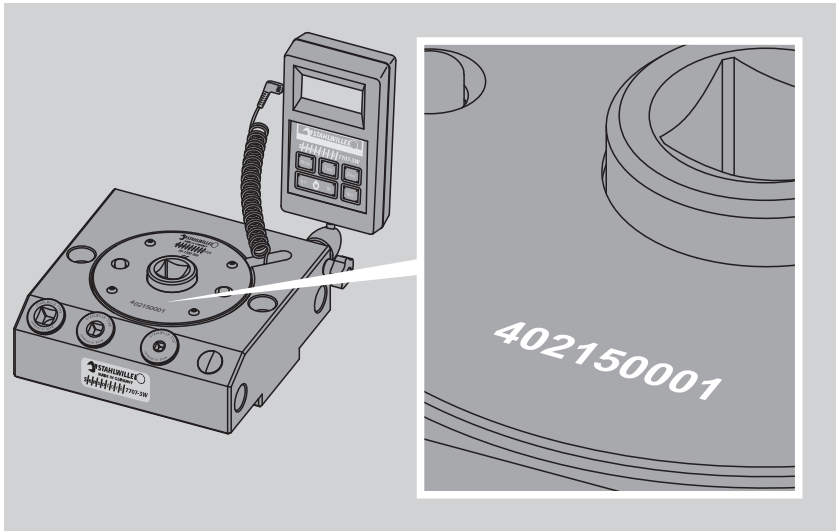

Serial number

Accuracy

The range of measurement is

- Sensotork 7707-1-2W, 7707-1-3W: 0,2 to 10 N m,
- Sensotork 7707-1W: 0,4 to 20 N m,
- Sensotork 7707-2W: 2 to 100 N m,
- Sensotork 7707-2-1W: 4 to 200 N m,
- Sensotork 7707-2-2W: 8 to 400 N m,
- Sensotork 7707-3W: 25 to 1100 N m.

The range of measurement according to the display variation of the individual models can be found in the tables below.

Sensotork 7707-1-2W, 7707-1-3W:

Display variation	N m	ft.lb	in.lb
± 1 % of value	0,2–10	0,15–7,4	1,8–88,5
± 0,5 % of value	1–10	0,75–7,5	9–88,5
± 0,25 % of value	2–10	1,5–7,5	17,5–88,5

Sensotork 7707-1W:

Display variation	N m	ft.lb	in.lb
± 1 % of value	0,4–20	0,3–15	3,5–177
± 0,5 % of value	2–20	1,5–15	18–177
± 0,25 % of value	4–20	3–15	35–177

Sensotork 7707-2W:

Display variation	N m	ft.lb	in.lb
± 1 % of value	2–100	1,5–74	18–885
± 0,5 % of value	10–100	7–74	89–885
± 0,25 % of value	12–100	9–74	106–885

Sensotork 7707-2-1W:

Display variation	N m	ft.lb	in.lb
± 1 % of value	4–200	3–148	35–1770
± 0,5 % of value	20–200	15–148	177–1770
± 0,25 % of value	40–200	30–148	354–1770

Sensotork 7707-2-2W:

Display variation	N m	ft.lb	in.lb
± 1 % of value	8–400	6–295	71–3540
± 0,5 % of value	40–400	30–295	354–3540
± 0,25 % of value	80–400	59–295	708–3540

Sensotork 7707-3W:

Display variation	N m	ft.lb	in.lb
± 1 % of value	25–1100	18–812	221–9736
± 0,5 % of value	110–1100	81–812	974–9736
± 0,25 % of value	220–1100	162–812	1947–9736

Additional details can be seen from the calibration certificate supplied with the unit.

Functional description

The torque to be determined is applied using an internal square drive.

Technical specifications

7707-1-2W and 7707-1-3W

Weight of the electronic workshop torque tester	6,255 kg
Weight of the display unit	0.190 kg
Weight of the stand	0.480 kg
Dimensions of the electronic workshop torque tester	width: 180 mm height: 215 mm depth: 180 mm
Dimensions of the display unit	width: 80 mm height: 145 mm depth: 38.5 mm
Range of measurement	0.2–10 Nm
Rated value	10 N m (with a maximum overload of 20% for a short time only)
Mains adapter power supply	110 V – 230 V AC
Display unit power supply	9–12 V DC
Transducer current consumption	maximum 60 mA

7707-1W

Weight of the electronic workshop torque tester	6,255 kg
Weight of the display unit	0,190 kg
Weight of the stand	0,480 kg
Dimensions of the electronic workshop torque tester	width: 180 mm height: 215mm depth: 180 mm
Dimensions of the display unit	width: 80 mm height: 145 mm depth: 38,5 mm
Range of measurement	0,4–20 Nm
Rated value	20 Nm (with a maximum overload of 20% for a short time only)
Power rating of the mains adaptor	110 V – 230 V AC
supply to the display unit	9–12 V DC
Current rating for a transducer / a display unit, in total	maximum 60 mA

7707-2W

Weight of the electronic workshop torque tester	7,025 kg
Weight of the display unit	0,190 kg
Weight of the stand	0,480 kg
Dimensions of the electronic workshop torque tester	width: 180 mm height: 215 mm depth: 180 mm
Dimensions of the display unit	width: 80 mm height: 145 mm depth: 38,5 mm
Range of measurement	2–100 Nm
Rated value	100 Nm (with a maximum overload of 20% for a short time only)
Power rating of the mains adaptor	110 V – 230 V AC
supply to the display unit	9–12 V DC
Current rating for a transducer / a display unit, in total	maximum 60 mA

7707-2-1W

Weight of the electronic workshop torque tester	7,511 kg
Weight of the display unit	0,190 kg
Weight of the stand	0,480 kg
Dimensions of the electronic workshop torque tester	width: 180 mm height: 215 mm depth: 180 mm
Dimensions of the display unit	width: 80 mm height: 145 mm depth: 38,5 mm
Range of measurement	4–200 Nm
Rated value	200 Nm (with a maximum overload of 20% for a short time only)
Power rating of the mains adaptor	110 V – 230 V AC
supply to the display unit	9–12 V DC
Current rating for a transducer / a display unit, in total	maximum 60 mA

7707-2-2W

Weight of the electronic workshop torque tester	7,654 kg
Weight of the display unit	0,190 kg
Weight of the stand	0,480 kg
Dimensions of the electronic workshop torque tester	width: 180 mm height: 215 mm depth: 180 mm
Dimensions of the display unit	width: 80 mm height: 145 mm depth: 38,5 mm
Range of measurement	8–400 Nm
Rated value	400 Nm (with a maximum overload of 20% for a short time only)
Power rating of the mains adaptor	110 V – 230 V AC
supply to the display unit	9–12 V DC
Current rating for a transducer / a display unit, in total	maximum 60 mA

7707-3W

Weight of the electronic workshop torque tester	7,495 kg
Weight of the display unit	0,190 kg
Weight of the stand	0,480 kg
Dimensions of the electronic workshop torque tester	width: 180 mm height: 215 mm depth: 180 mm
Dimensions of the display unit	width: 80 mm height: 145 mm depth: 38,5 mm
Range of measurement	25–1100 Nm
Rated value	1100 Nm (with a maximum overload of 20% for a short time only)
Power rating of the mains adaptor	110 V – 230 V AC
supply to the display unit	9–12 V DC
Current rating for a transducer / a display unit, in total	maximum 60 mA

Transport, items supplied, storage

Transport

Transport the electronic workshop torque tester, the transducer and display unit only in the case supplied and ensure that the case cannot be dislodged and cannot fall in transit.

ATTENTION!

Damage to and decalibration of the electronic workshop tester.

- Do not expose the aluminium mounting block, the transducer or the display unit to impacts.
 - Do not throw the electronic workshop tester or its components.
-

Items included

Electronic workshop torque tester, model 7707-1W

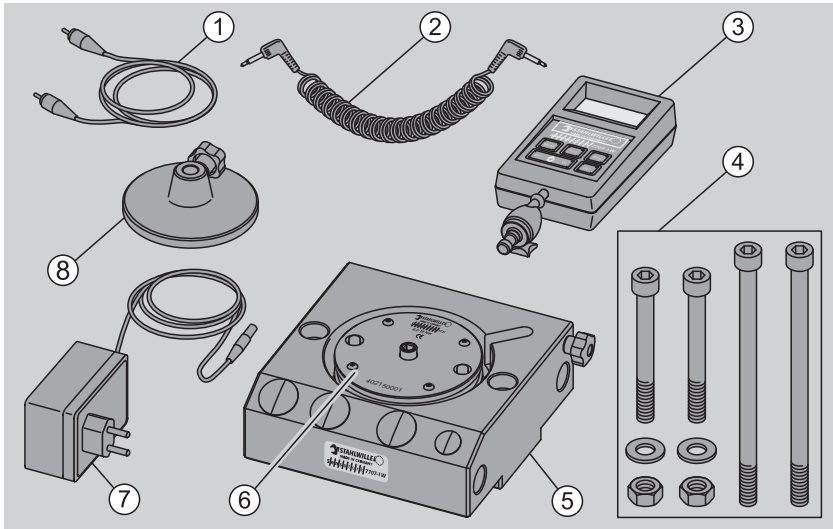

1	1.5 m jack cable for connecting the display unit to the transducer if the stand is used, Order no. 7751.
2	Spiral lead for connecting the display unit to the transducer, Order no. 7752
3	Display unit and holder, Order no. 7750
4	Attachment set: <ul style="list-style-type: none">• two retaining screws M 12 x 220, 8.8 to DIN ISO 912• two retaining screws M 12 x 120, 8.8 to DIN ISO 912• two M 12 nuts• two U 13 washers
5	Aluminium mounting block
6	Transducer, Order no. 7721-1
7	Mains adaptor (110 V – 230 V AC) with lead for connecting to the display unit, Order no. 7760
8	Stand
Operating Instructions, Code 91979782	

Differing and additional scope of supplies for the Sensotork 7707-1-3W electronic workshop torque tester

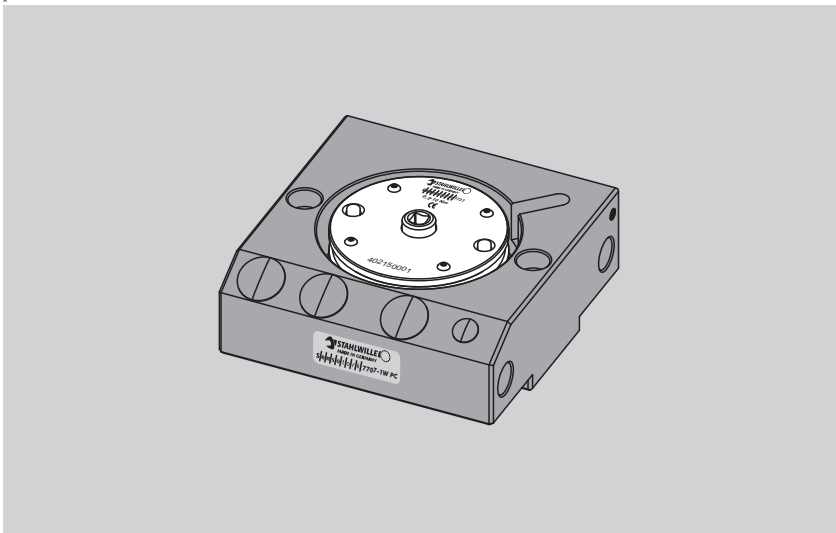

- Measurement sensor, Part no. 7721
- Software CD ROM, Part no. 7731
- USB adaptor, Part no. 7757-1
- Not supplied:
 - Helix cable, Part no. 7752
 - Display with mounting, Part no. 7750
 - Mains adaptor, Part no. 7760
 - stand



Differing or additional scope of delivery for the Sensotork 7707-1-2W electronic workshop torque tester



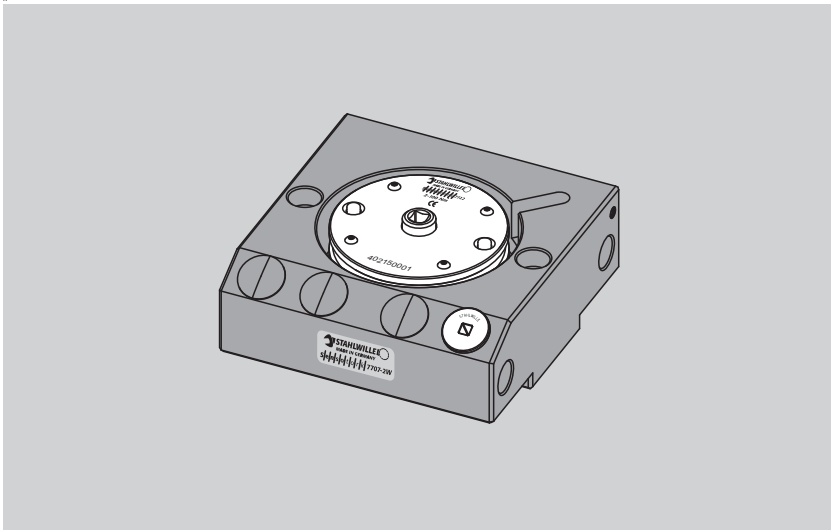

- Transducer, part No. 7721-0
- Software CD ROM, part No. 7731
- USB adapter, part No. 7757-1
- Not contained in delivery:
 - Spiral cable, part No. 7752
 - Display unit with mounting, part No. 7750
 - Mains adapter, part No. 7760
 - Stand

Differing and additional scope of supplies for the Sensotork 7707-2W electronic workshop torque tester

- Transducer, Order no. 7722
- Adapter from 1/4"  to 3/8" , Order no. 409M







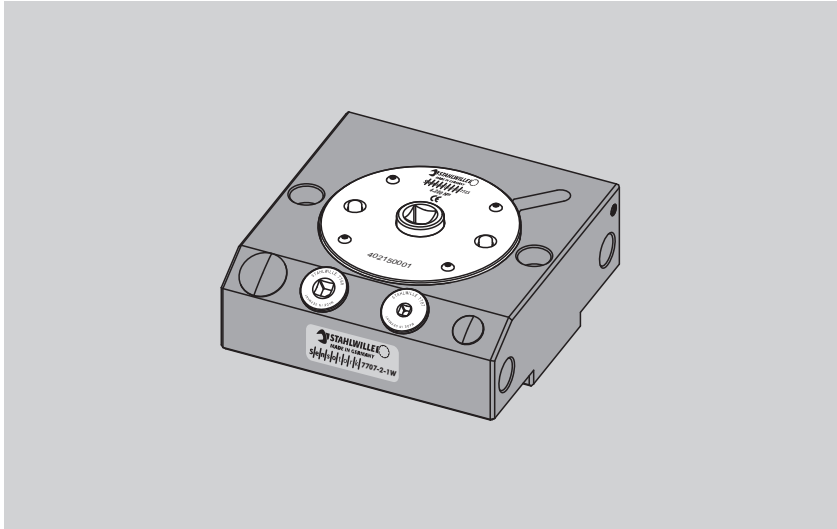

Differing and additional scope of supplies for the Sensotork 7707-2-1W electronic workshop torque tester

- Transducer, Order no. 7723-1
- Adapter from 1/4"  to 1/2" , Order no. 7789-4
- Adapter from 3/8"  to 1/2" , Order no. 7789-5







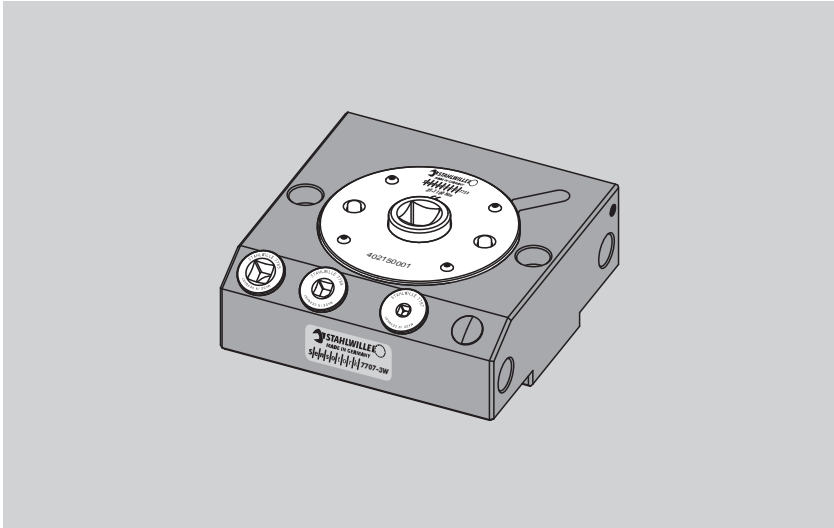

Differing and additional scope of supplies for the Sensotork 7707-2-2W electronic workshop torque tester

- Transducer, Order no. 7723-2
- Adapter from 1/4"  to 3/4" , Order no. 7787
- Adapter from 3/8"  to 3/4" , Order no. 7788
- Adapter from 1/2"  to 3/4" , Order no. 7789



Differing and additional scope of supplies for the Sensotork 7707-3W electronic workshop torque tester

- Transducer, Order no. 7723-3
- Adapter from 1/4"  to 3/4" , Order no. 7787
- Adapter from 3/8"  to 3/4" , Order no. 7788
- Adapter from 1/2"  to 3/4" , Order no. 7789

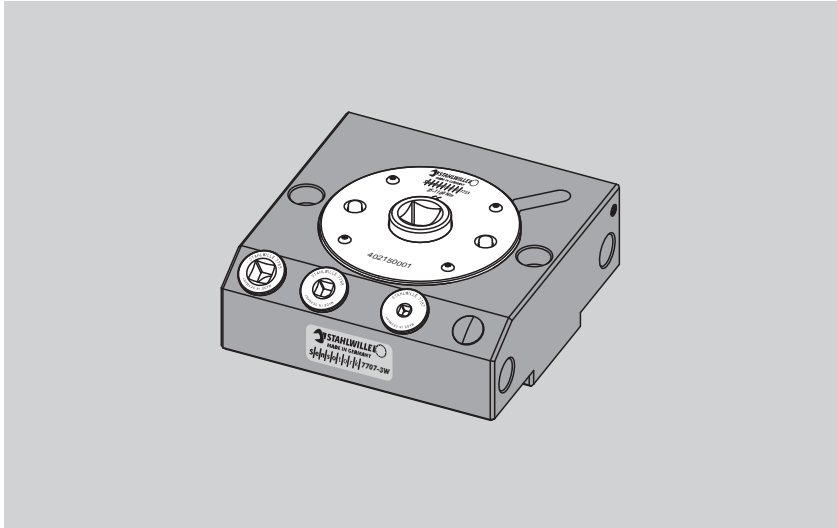

Optional accessories

In addition, it is possible to purchase a USB adaptor (Order no. 7757) and software (Order no. 7731). This USB adaptor with the jack cable (Order no. 7751) allows the transducer instead of the display unit to be connected directly to the PC.

The USB adaptor, jack cable and software together enable you

- to generate calibration certificates in accordance with DIN EN ISO 6789 and
- to record the readings you take.

PC requirements

- USB 1.1 or 2.0 ports
- Operating system Microsoft Windows[®] XP or higher.

Storage

Store all components supplied in such a way that they are

- safe from damage,
- dry and
- at an ambient temperature of between -20 °C and $+80\text{ °C}$.

Leave all the components in the case until required for assembly.

Preparing and mounting the electronic workshop torque tester

General fitting instructions

When selecting the best place for mounting the unit, take all relevant legal provisions and safety regulations into consideration.

- The user must be able to take up a comfortable, firm stance.
- The user must have sufficient space around him to be able to move freely.
- Lighting must be good.
- The ambient temperatures during testing must be between -20 °C and $+60\text{ °C}$.
- The electronic torque tester must be allowed to acclimatise to ambient temperature and humidity for at least one hour before it is used.
- The electronic torque tester must always be protected against dirt, damp and other damaging influences.
- The application environment must be free from all vibration and shock.

Mounting the electronic workshop torque tester



CAUTION

Risk of injury due to incorrect fastening of the electronic workshop tester.

- Make sure that the electronic workshop tester is fastened sufficiently.
 - Fasten the electronic workshop tester only at the holes intended for this.
 - Fasten the electronic workshop tester using the specified bolts only.
-

In order to work with the electronic torque tester, it must first be firmly attached to a solid base. The foundation must be extremely sturdy, such as a fitted worktop. The thickness of the worktop must be between 30 and 50 mm.

- For horizontal fixing, use the M 12 x 120, 8.8 Allen-head screws in accordance with DIN ISO 912 as supplied and
- for vertical fixing use only the M 12 x 220, 8.8 Allen-head screws in accordance with DIN ISO 912 as supplied.

ATTENTION!

Decalibration due to incorrect fastening of the electronic workshop tester.

- Fasten the electronic workshop tester only at the holes intended for this.
-
- Using the holes intended for the purpose, screw the electronic workshop torque tester to the worktop firmly enough to ensure that it will take the loads applied to it when testing torque values (refer to the illustrations on the following pages).
 - Lock every Allen-head screw using a washer and nut from the attachment set supplied.

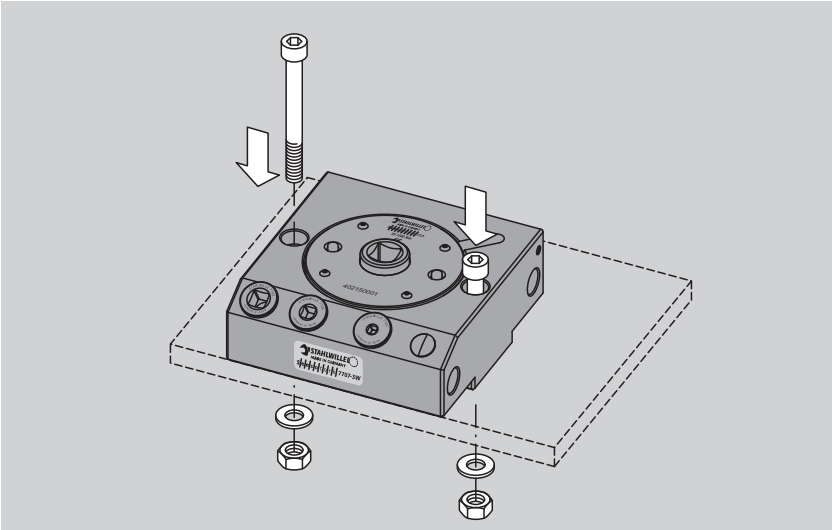

Lock every Allen-head screw using a washer and nut from the attachment set supplied.

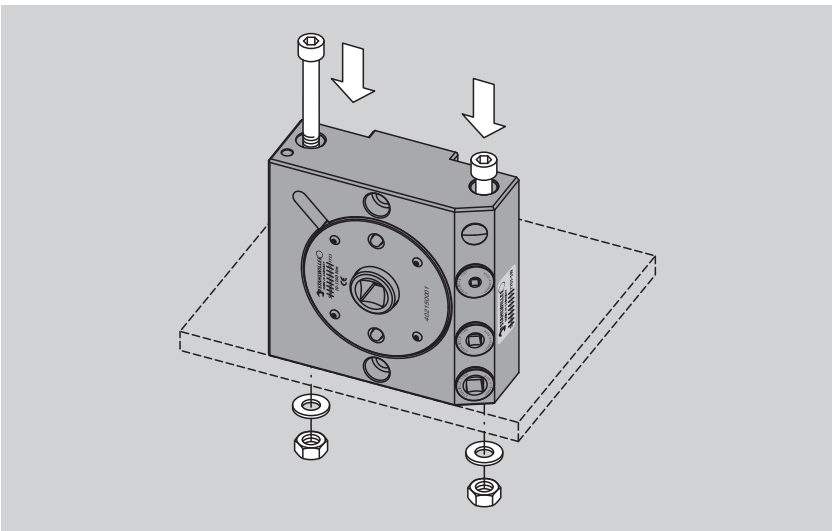

Vertical attachment of the electronic workshop torque tester

Attaching the display unit

The display unit can be attached to the aluminium mounting block using a holder.

If you prefer not to attach the display unit directly to the mounting block, it can be held in the stand. This might be necessary if, for example, the indicating torque wrench is a long-handled one, see „Fixing the display unit on the stand” on page 36.

Attaching the display unit to the mounting block

- Release the clamping screw. To do so, turn the clamping screw anticlockwise.
- Insert the pin of the holder all the way into the hole.

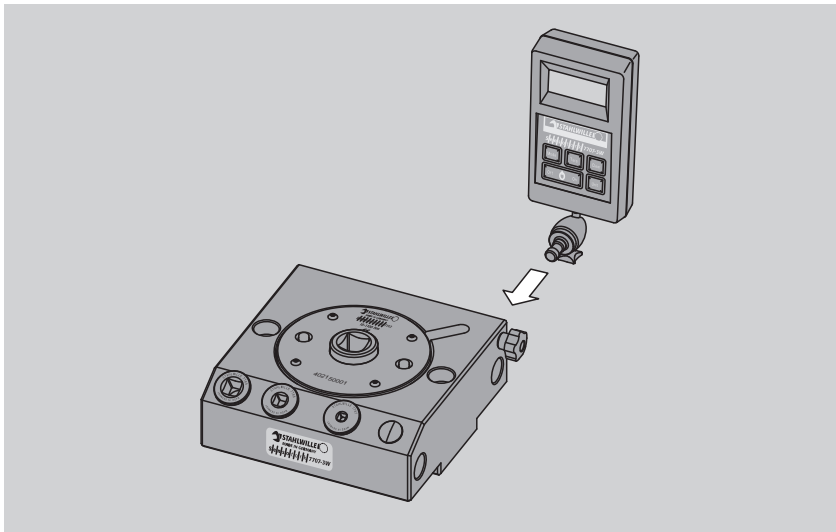

Inserting the holder in the hole

→ Clamp the holder with the clamping screw. To do so, turn the clamping screw clockwise as far as it will go.

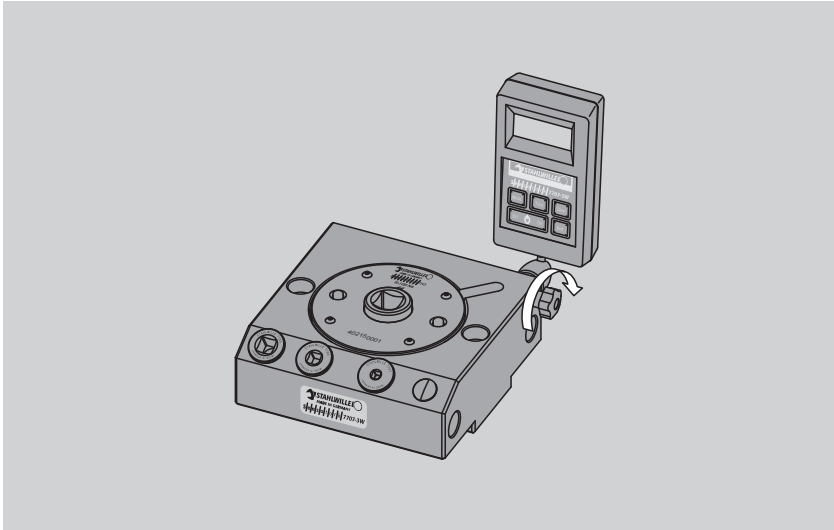

Clamping the holder

Aligning the display unit

You can

- turn the display unit in its holder and
 - tilt it to the front,
 - rear or
 - to the sides.
- The display unit can be adjusted to meet your personal preferences.

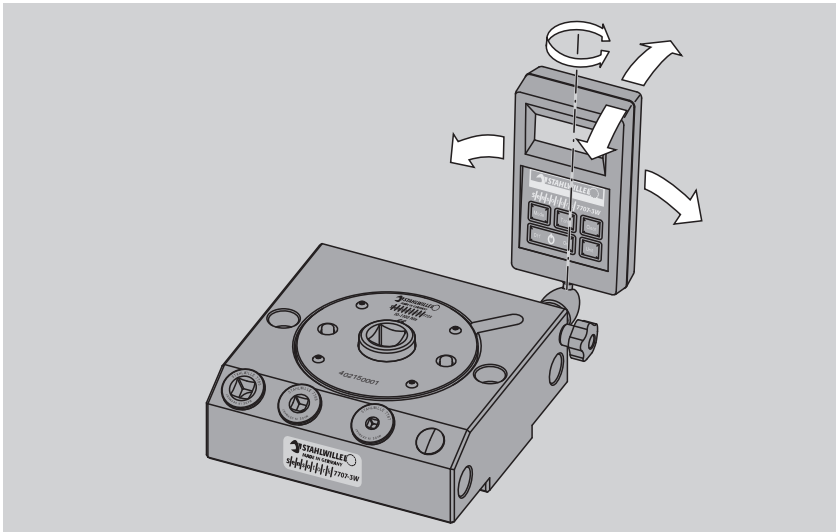

Adjusting the display unit

Clamping the holder

- Prevent the holder from being inadvertently adjusted. To do so, turn the clamping screw as far as it will go.

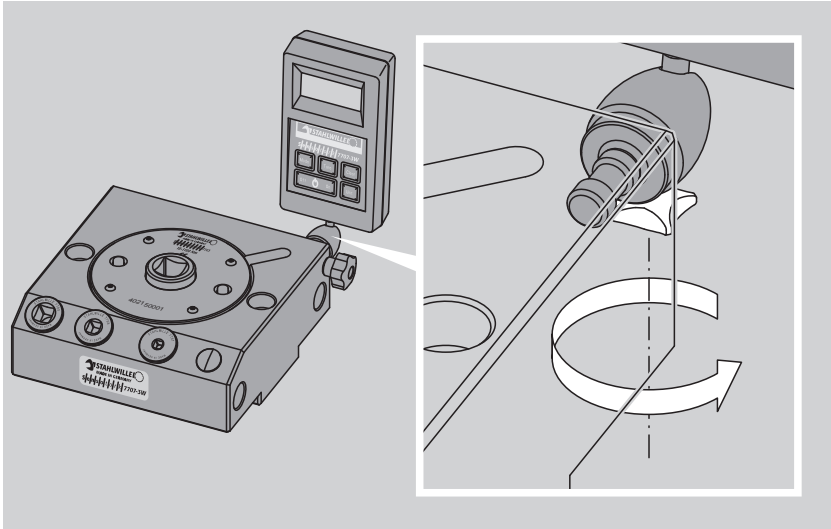

Preventing the holder from being inadvertently adjusted

Fixing the display unit on the stand

- Release the clamping screw on the stand.
- Insert the pin of the display unit, which is now attached to the holder, into the stand (1) as far as it will go.

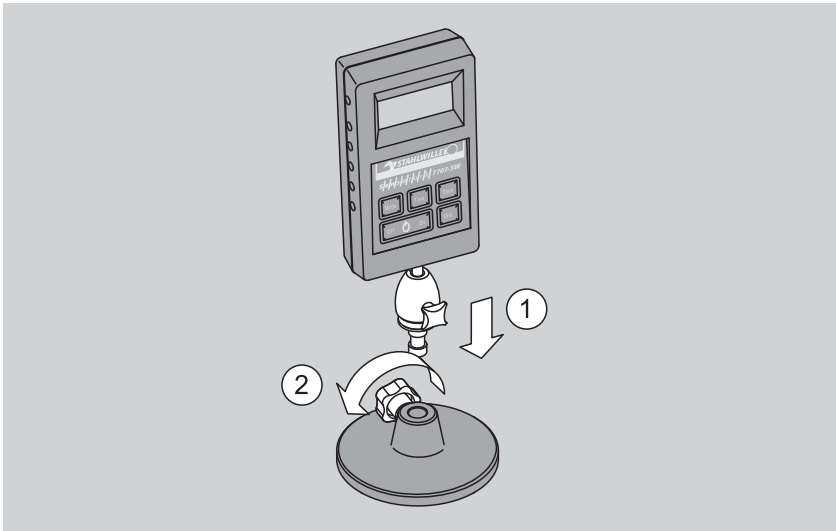

Attaching the display unit to the stand.

- Lock the holder with the clamping screw (2).

Example for fitting the display unit on the stand for use with indicating torque wrenches with long handles:

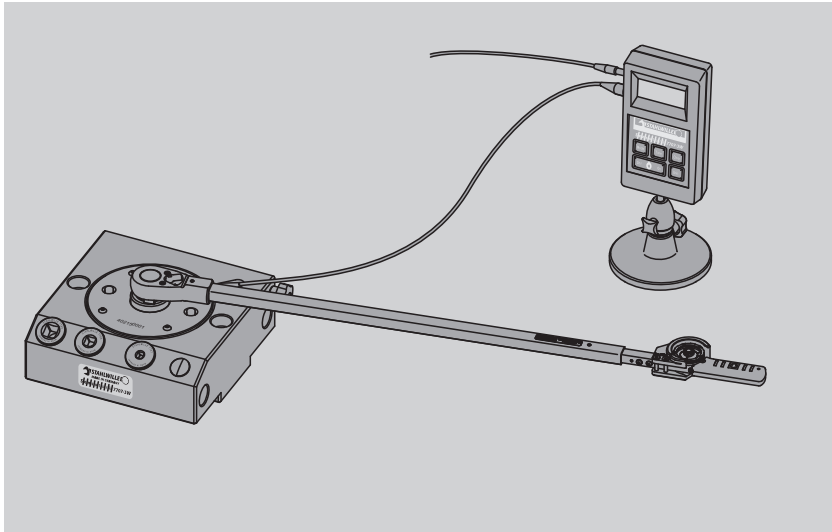

Inserting and removing transducers

The QuickRelease safety lock enables you to safely lock the transducer in place and release it easily when required.

Inserting the transducer

- Hold the transducer firmly with both hands.
- Position the transducer vertically in the round hole in the aluminium mounting block.
- Press the two green release buttons and keep them depressed until you have inserted the locating pins in the holes.
- Then, press the transducer down until you hear a clearly audible "click".

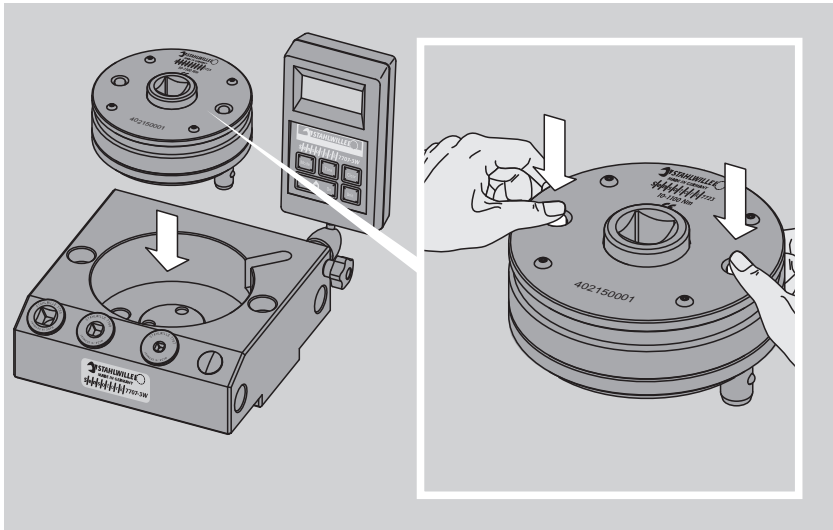

Inserting and locking the transducer

Releasing the transducer

→ Press the two green release buttons.

The transducer will be automatically ejected by about 1 cm.

→ Extract the transducer vertically from the mounting block.

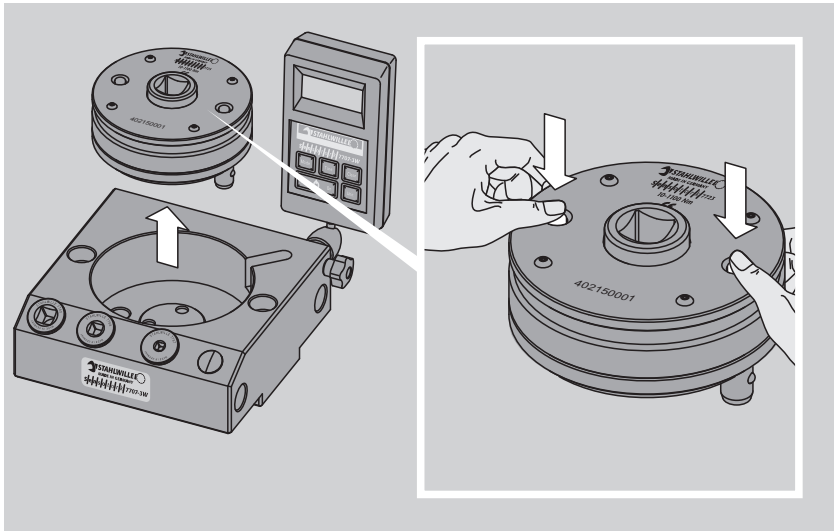

Releasing and removing the transducer

Connecting the display unit

ATTENTION!

Damage to the electronic display unit due to use of an incorrect plug-in power supply unit.

→ Use the enclosed plug-in power supply unit exclusively.

- Connect up the mains cable of the mains adapter to the display unit. To do so, insert the plug in the uppermost socket on the left-hand outer side of the display unit.

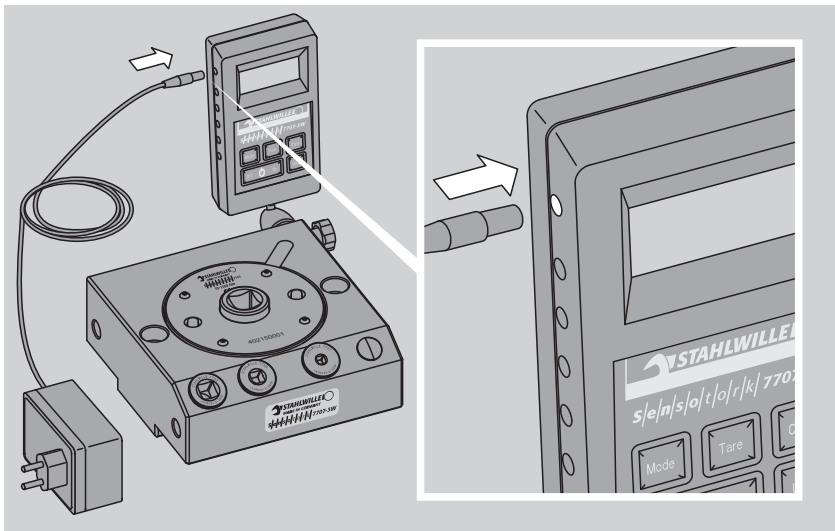

Connecting the mains cable to the display unit

→ Next, connect the spiral or jack cable to the transducer using the 3.5 mm jack.

The spiral or jack cable can be connected up either way round.

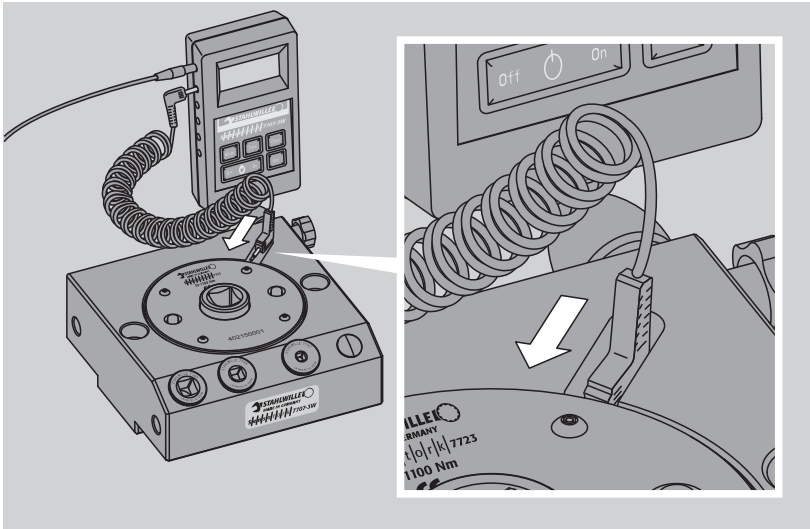

Connecting the spiral or jack cable to the transducer

- Connect the other end to one of the five remaining sockets on the left-hand outer side of the display unit.

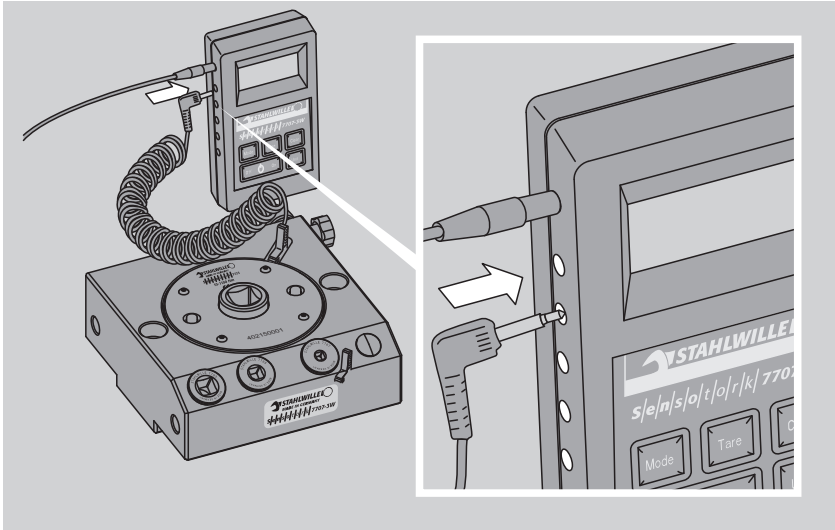

Connecting the spiral or jack cable to the display unit

- ☞ The display unit can be connected to up to five transducers simultaneously. In this way, you only require one display unit. The display unit displays the readings of whichever transducer is currently registering a torque input.

ATTENTION!

Damage to the electronic display unit due to use of an incorrect plug-in power supply unit.

- Use the enclosed plug-in power supply unit exclusively.
 - Make sure that the specifications on the plug-in power supply unit model plate correspond to those of the mains connection.
 - Contact STAHLWILLE if the power supply unit specifications do not correspond to the mains connection specifications.
-

- Next, connect the mains adaptor to a mains outlet.

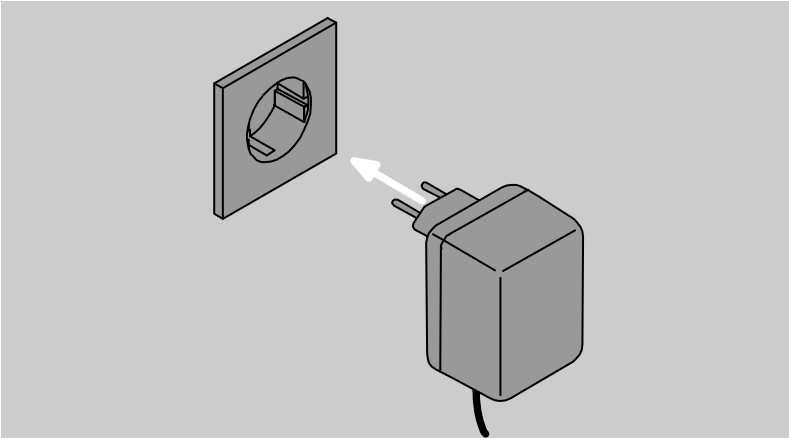

Connecting the mains adaptor

Connecting a USB-adaptor (optional)

- Plug a jack from the jack cable into the USB adaptor and the other into the measurement sensor.
- To ensure a secure connection to the PC, the corresponding USB driver software must be installed before connecting the USB adaptor to the PC.

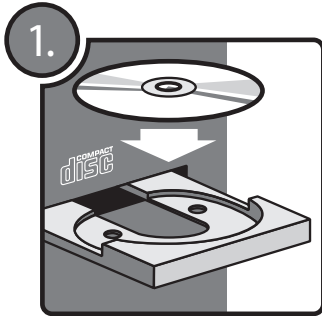

- Then, connect the USB-adaptor to a free USB interface on your PC.

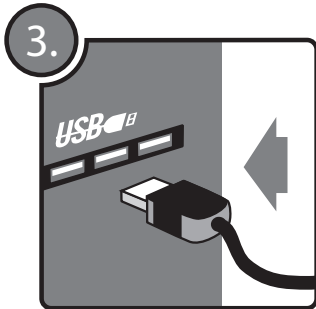

- ☞ If you have first inserted the USB plug, then please follow the prompt to install a driver by inserting the CD ROM. In the event of further error messages please consult your administrator..

Switching the display unit on and off

- If you wish to turn on the display unit, press the ON button and keep it pressed until the display lights up.

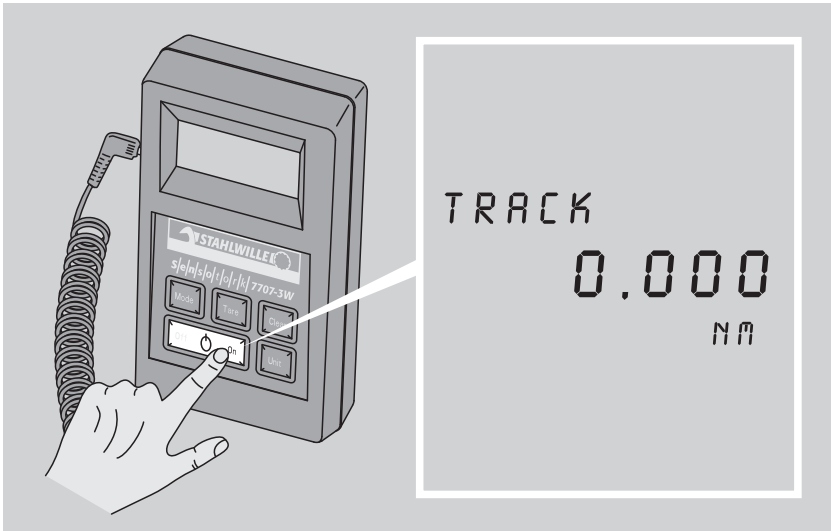

Turning on the display unit

→ To turn off the display unit, press the OFF button.

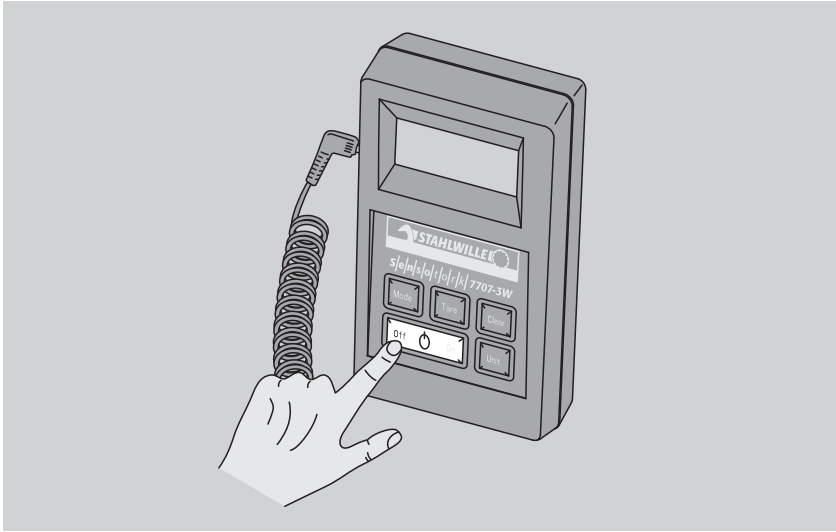

Switching off the display unit

Testing a torque wrench or torque screwdriver

ATTENTION!

Damage due to incorrect handling of the torque wrench to be tested.

- Observe and comply with the information in the torque wrench operating instructions.
- In particular, observe and comply with the safety instructions, the technical limit values and the information on calibration and adjustment.

Before carrying out measurements, it is necessary to reset (zero) the unit. When the display unit is switched on, it automatically performs a zeroing procedure i.e. the display is reset to 0 Nm.

Inserting the torque wrench or torque screwdriver

ATTENTION!

Incorrect measurement results due to simultaneous use of several square adapters.

- Do not use more than one square adapter simultaneously.
 - Use only the enclosed square adapters.
-

If the outer square drive of the torque wrench or torque screwdriver does not match the internal square drive of the transducer, you can use a square drive adapter. The size of the square drive adapter will depend on the outer square drive on the torque wrench or torque screwdriver to be tested.

→ If you wish to use a square drive adapter, attach it first to the transducer.

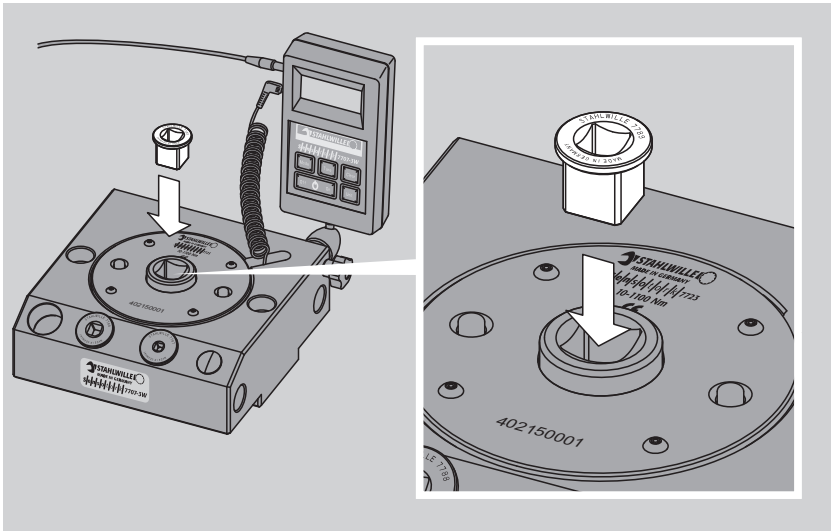

Attaching the square drive adapter to the transducer

- Connect a torque wrench, torque screwdriver or another tool to be tested to the transducer.

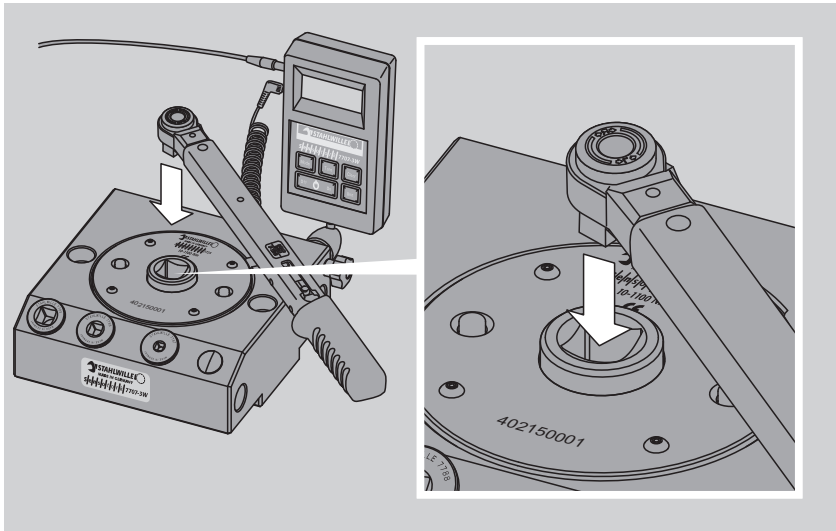

Inserting the torque wrench in the transducer

Reading off measurements via the display unit

The display unit can display three different modes:

- Track: for general torquing jobs
- Peak Hold: for indicating torque wrenches or torque screwdrivers
- First Peak: for clicking torque wrenches or torque screwdrivers

In addition, the display unit has a "Units" button for converting the units of measurement.

You can read and test torque in both a clockwise and anticlockwise direction.

General torquing

→ Press the "Mode" key until the display shows "TRACK".

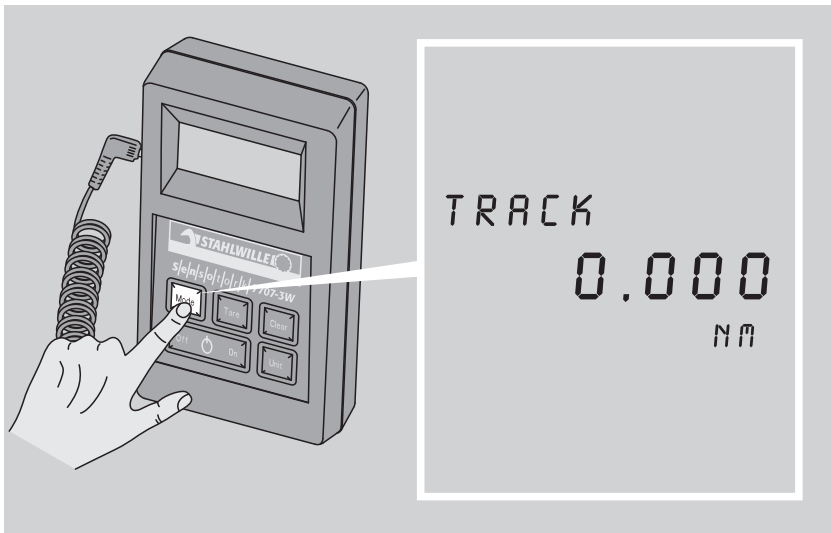

"Track" mode

- Apply slow, even force to the torque wrench or torque screwdriver in the desired direction after it is attached and observe the reading shown on the display unit.

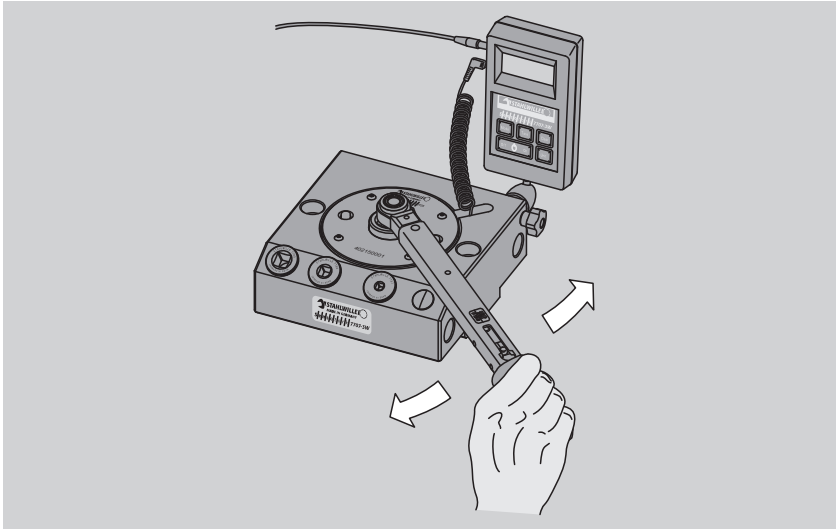

Applying force to the torque wrench

The "TRACK" mode displays the torque currently applied to the tool.

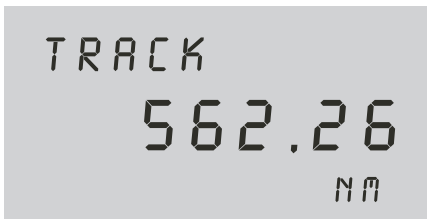

Display in "Track" mode showing the torque reading

- If you wish to set the current torque as the zero setting, press the "Tare" key.

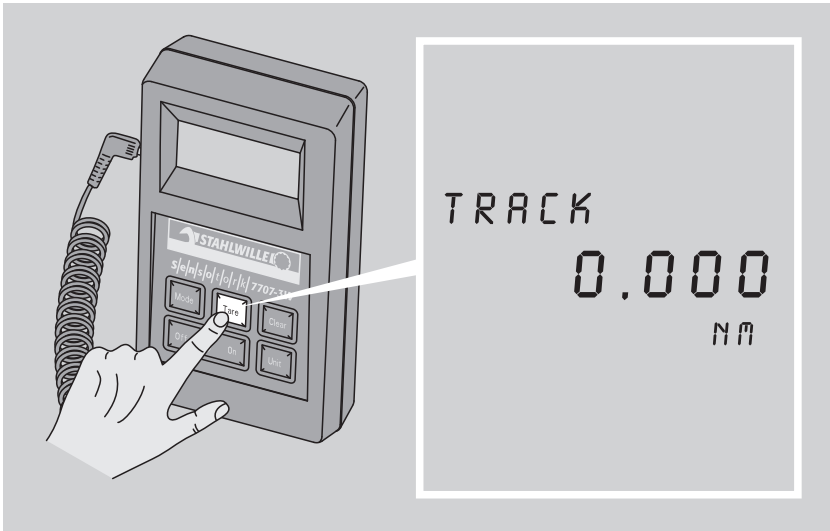

Pressing the "Tare" key

The currently displayed torque is set to 0 Nm.

- ➡ Only press this key when the transducer is at rest, ie there is no load on it as otherwise the readings will be inaccurate.
- ➡ Values that are not equal to 0.000 may occur after taring. These values should remain inside the required accuracy range. If this is not the case, repeat the taring process.

Testing indicating torque wrenches or torque screwdrivers

→ Press the "Mode" key until the display shows "PEAK HOLD".

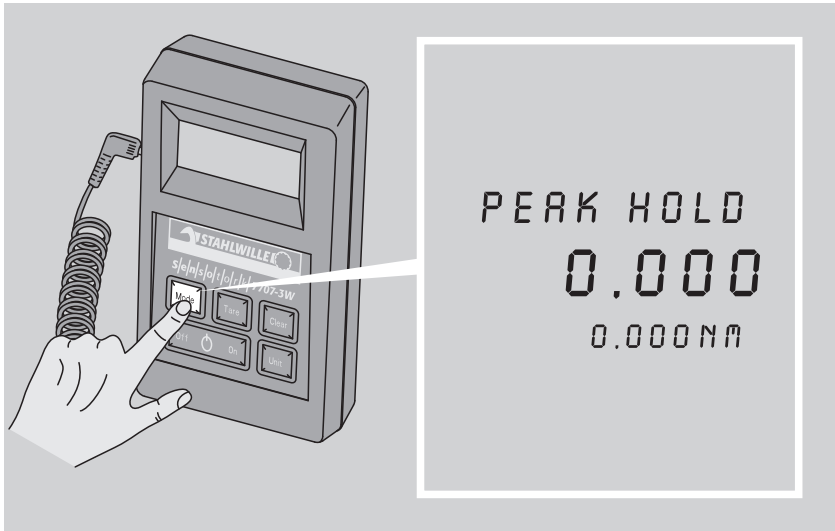

"Peak Hold" mode

- Apply force uniformly to the torque wrench or torque screwdriver in the desired direction and observe the reading on the display unit.

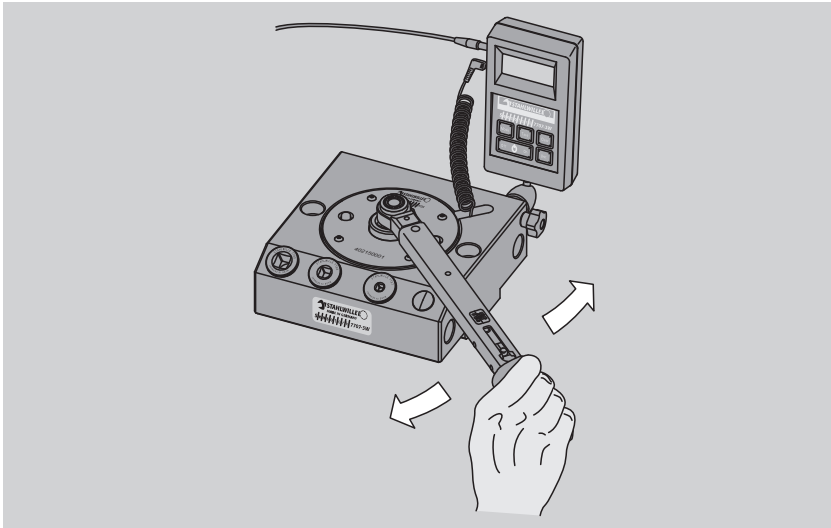

Applying force to the torque wrench

- Compare the readings to see if that on the torque wrench or torque screwdriver coincides with that on the display unit.



Display in "Peak Hold" mode showing torque readings

The number shown in large figures shows the greatest torque applied up to that point (peak). The smaller number represents the currently applied torque.

→ To delete the peak reading, press "Clear".

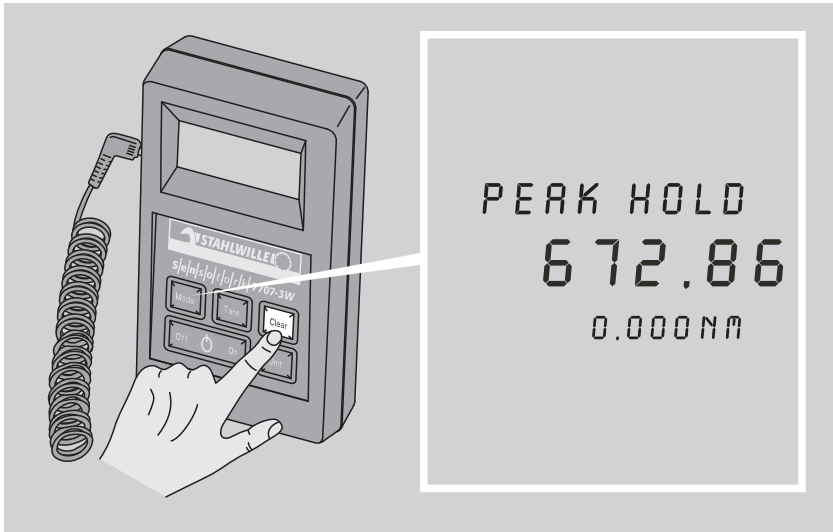

Pressing the "Clear" button



If you press this key during testing, the currently applied torque immediately becomes the new peak.

If you notice any deviation between the values, adjust the torque wrench or torque screwdriver as explained in the appropriate Operating Instructions and then test the torque wrench or torque screwdriver again.



WARNING

Accidents possible due to incorrect torque with incorrectly adjusted torque wrenches.

- Do not use torque wrenches with incorrect values.
- Adjust the torque wrench properly prior to further use.

Testing a clicking torque wrench or torque screwdriver

→ Press the "Mode" key until the display shows "FIRST PEAK".



Display in "First Peak" mode

- Apply force slowly and uniformly to the tool in the desired direction and compare the reading on the display of the display unit with the value preset on the torque wrench or torque screwdriver.

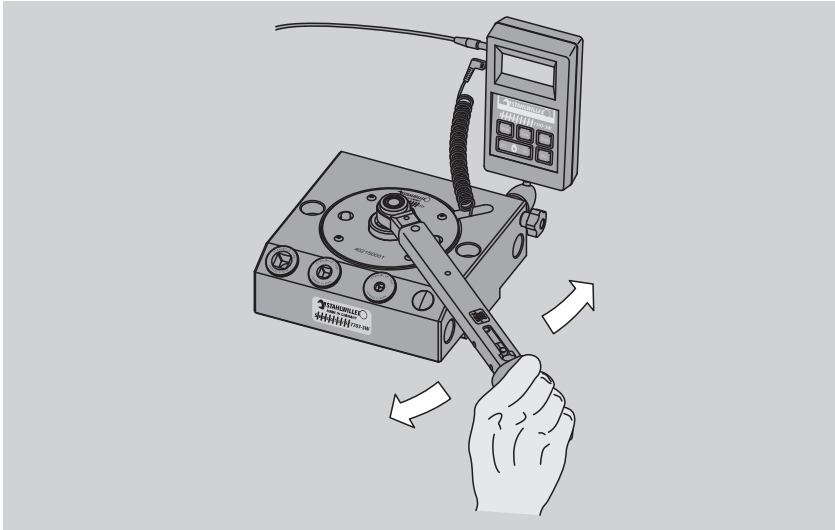

Applying force to the torque wrench

The number shown in large figures is the First Peak reading. It was at this value that the torque wrench or torque screwdriver tripped. The number in smaller figures represents the peak torque actually applied.



Display in "First Peak" mode showing torque readings

The torque wrench or torque screwdriver should trip at exactly the preset torque value.

- To delete the First Peak and largest torque to date, press "Clear".

-  In the "First Peak" mode, it is not necessary to press the "Clear" button. These peak readings will be automatically deleted as soon as you release pressure on the transducer and then apply new pressure.

- Compare the readings to see if the torque wrench or torque screwdriver trips at exactly the value shown on the display unit.

If you note deviations from the correct value, adjust your torque wrench or torque screwdriver as described in the Operating Instructions provided with it and then retest the torque wrench or torque screwdriver.



WARNING

Accidents possible due to incorrect torque with incorrectly adjusted torque wrenches.

- Do not use torque wrenches with incorrect values.
 - Adjust the torque wrench properly prior to further use.
-

Converting units of measure ("Unit" button)

Every time the "Unit" button is pressed the units of measurement shown on the display change and the readings are automatically converted. The first time the "Unit" button is pressed, the units will change from "Nm" to the other units of measurement like "cNm", "ft.lb" and "in.lb". The default unit of measurement is "Nm".

You can change the units

- before,
- during or
- after

making a measurement.

→ Press the "Unit" button repeatedly until the display shows the required units.

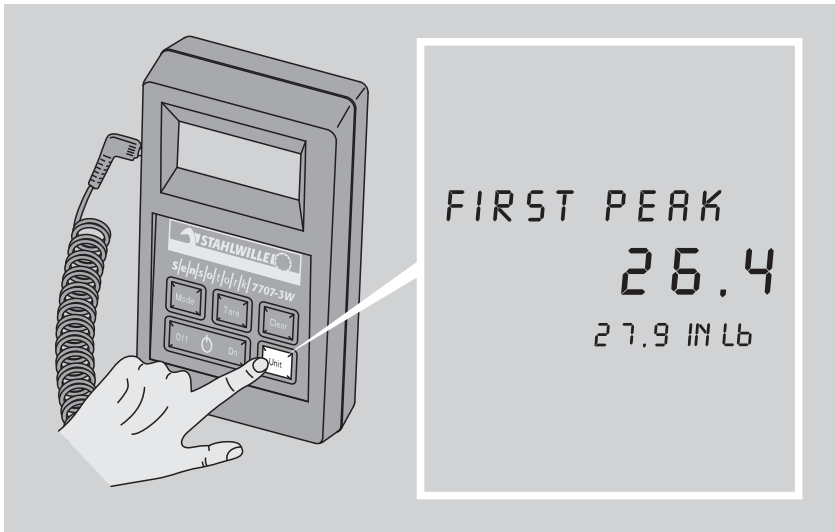

Pressing the "Unit" button

Maintenance and cleaning

The electronic workshop torque tester and its display unit are maintenance free. However, please note the instructions on calibrating and adjusting.

- Clean the electronic workshop torque tester and display unit using a soft, dry cloth only.

ATTENTION!

Malfunctions or damage to the electronic workshop tester due to incorrect cleaning.

- Do not use water, cleaning agents or solvents for cleaning.
-

Repairs, calibration and adjustment

If an electronic torque tester becomes defective or malfunctions, it is essential that it is repaired and adjusted.

Repairs may only be carried out by STAHLWILLE.

Calibration and adjustment of the electronic workshop torque tester may only be performed by an accredited testing laboratory, in Germany this is, eg a DKD approved laboratory. If you wish to make use of STAHLWILLE's calibration service, please send us only the transducer. You can find further details of STAHLWILLE's calibration service on the world-wide web: www.stahlwille.de

Electronic workshop torque testers for torque wrenches or torque screwdrivers are precision testing instruments. The calibration frequency will depend on such factors as

- the accuracy of the transducer,
- frequency of use,
- the typical loads applied during use,
- ambient conditions during use and
- the storage conditions when not in use.

The intervals for calibrating and adjusting this tester are equivalent to the processes applied at your company for test equipment inspection.

If your company has no defined test equipment inspection processes, have the electronic torque tester for torque wrenches or torque screwdrivers calibrated and adjusted at least once every 12 months.

Please ensure all other regulations applicable at the location are applied.

Disposal



Do not under any circumstances throw your electronic workshop torque tester and its accessories away with normal household refuse. Your local town or city council will offer environmentally friendly disposal options for such equipment. Adhere to local regulations regarding Directive 2002/96/EG (WEEE).

- The mounting block is made of aluminium,
- the transducer is steel,
- the holder for the display unit is steel and
- ABS plastic and the housing of the display unit is ABS plastic.

In addition, both the transducer and display unit contain electronic components which must be disposed of separately.

WEEE-register number: DE 70431151 EAR

WEEE = Waste Electrical and Electronical Equipment
(Waste electrical and electronic equipment)



Eduard Wille GmbH & Co. KG
P.O. Box 12 01 03 D-42331 Wuppertal
Lindenallee 27 D-42349 Wuppertal
Germany
Tel: +49/202/47 91-0
Fax: +49/202/47 91-200
support@stahlwille.de
www.stahlwille.de